

Simple Step-Up Fixed Voltage Regulators

FEATURES

- Requires Few External Components
- NPN Output Switches 3.0A, 65V(max)
- Extended Input Voltage Range: 3.0V to 40V
- Current Mode Operation for Improved Transient Response, Line Regulation, and Current Limiting
- Soft Start Function Provides Controlled Startup
- 52kHz Internal Oscillator
- Output Switch Protected by Current Limit, UVLO and Thermal Shutdown
- Improved Replacement for LM2577 Series

DESCRIPTION

The UC2577 family of devices provides all the active functions necessary to implement step-up (boost), flyback, and forward converter switching regulators. Requiring only a few components, these simple regulators efficiently provide fixed output voltages of 12V or 15V as step-up regulators.

The UC2577 series features a wide input voltage range of 3.0V to 40V. An on-chip 3.0A NPN switch is included with undervoltage lockout, thermal protection circuitry, and current limiting, as well as soft start mode operation to reduce current during startup. Other features include a 52kHz fixed frequency on-chip oscillator with no external components and current mode control for better line and load regulation.

For Applications Information, see the UC2577-ADJ data sheet, Design Note DN-48 "Versatile Low Power SEPIC Converter Accepts Wide Input Voltage Range", and Design Note DN-49 "UC2577 Easy Switcher Controls SEPIC Converter for Automotive Applications".

TYPICAL APPLICATIONS

- Simple Boost and Flyback Converters
- Transformer Coupled Forward Regulators
- SEPIC Topology Permits Input Voltage to be Higher or Lower than Output Voltage
- Multiple Output Designs

BLOCK DIAGRAM

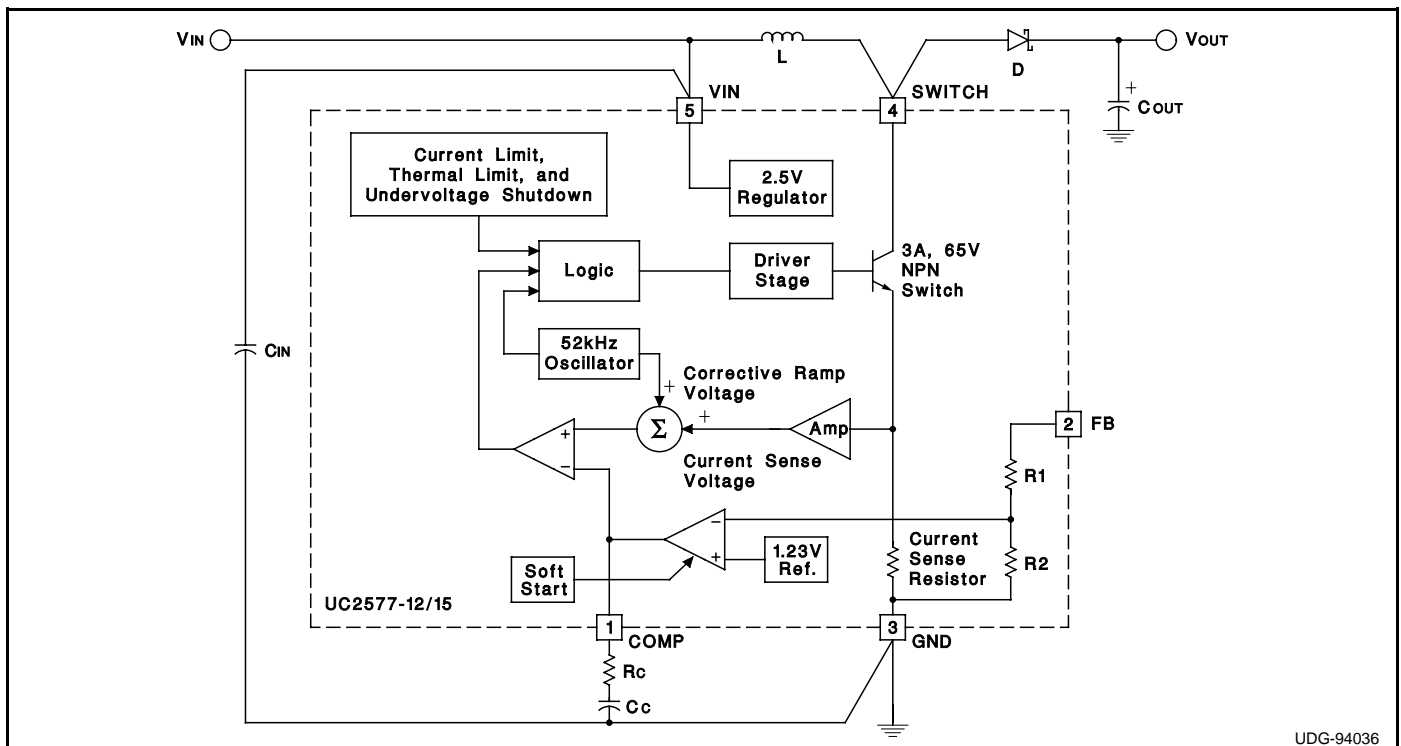

UC2577-12

ABSOLUTE MAXIMUM RATINGS (Note 1)

Supply Voltage	45V
Output Switch Voltage	65V
Output Switch Current (Note 2)	6.0A
Power Dissipation	Internally Limited
Storage Temperature Range	-65°C to +150°C
Lead Temperature (Soldering, 10 sec.)	260°C
Maximum Junction Temperature	150°C
Minimum ESD Rating (C = 100pF, R = 1.5kΩ)	2kV

CONNECTION DIAGRAM

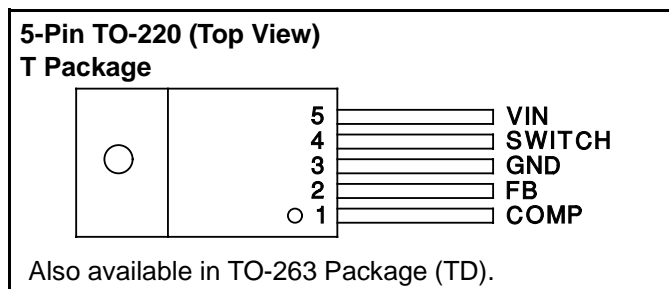

RECOMMENDED OPERATING RANGE

Supply Voltage	$3.0V \leq V_{IN} \leq 40V$
Output Switch Voltage	$0V \leq V_{SWITCH} \leq 60V$
Output Switch Current	$I_{SWITCH} \leq 3.0A$
Junction Temperature Range	$-40^\circ C \leq T_J \leq +125^\circ C$

ORDERING INFORMATION

UC2577T-12	5 Pin TO-220 Plastic Package
UC2577T-15	5 Pin TO-220 Plastic Package
UC2577TD-12	5 Pin TO-263 Plastic Package
UC2577TD-15	5 Pin TO-263 Plastic Package

ELECTRICAL CHARACTERISTICS Unless otherwise stated, these specifications apply for $T_A = -40^\circ C$ to $+125^\circ C$, $V_{IN} = 5V$, $I_{SWITCH} = 0$, and $T_A = T_J$.

PARAMETER	TEST CONDITIONS	UC2577-12			
		MIN	TYP	MAX	UNITS
System Parameters Circuit Figure 1 (Note 3)					
Output Voltage	$V_{IN} = 5V$ to $10V$, $I_{LOAD} = 100mA$ to $800mA$	11.40	12.0	12.60	V
	$T_J = 25^\circ C$	11.60		12.40	V
Line Regulation	$V_{IN} = 3.0V$ to $12V$, $I_{LOAD} = 300mA$		20	100	mV
	$T_J = 25^\circ C$			50	mV
Load Regulation	$V_{IN} = 5V$, $I_{LOAD} = 100mA$ to $800mA$		20	100	mV
	$T_J = 25^\circ C$			50	mV
Efficiency	$V_{IN} = 5V$, $I_{LOAD} = 800mA$		80		%
Device Parameters					
Input Supply Current	$V_{FB} = 14V$ (Switch Off)		7.5	14	mA
	$T_J = 25^\circ C$			10	mA
	$I_{SWITCH} = 2.0A$, $V_{COMP} = 2.0V$ (Max Duty Cycle)		45	85	mA
	$T_J = 25^\circ C$			70	mA
Input Supply UVLO	$I_{SWITCH} = 100mA$		2.70	2.95	V
	$T_J = 25^\circ C$			2.85	V
Oscillator Frequency	Measured at SWITCH Pin, $I_{SWITCH} = 100mA$	42	52	62	kHz
	$T_J = 25^\circ C$	48		56	kHz
Output Reference Voltage	Measured at FB Pin, $V_{IN} = 3.0V$ to $40V$, $V_{COMP} = 1.0V$	11.64	12	12.36	V
	$T_J = 25^\circ C$	11.76		12.26	V
Reference Voltage Line Regulation	$V_{IN} = 3.0V$ to $40V$		7		mV
FB Pin Input Resistance			9.7		kΩ
Error Amp Transconductance	$I_{COMP} = -30\mu A$ to $+30\mu A$, $V_{COMP} = 1.0V$	145	370	615	μmho
	$T_J = 25^\circ C$	225		515	μmho
Error Amp Voltage Gain	$V_{COMP} = 0.8V$ to $1.6V$, $R_{COMP} = 1.0M\Omega$ (Note 4)	25	80		V/V
	$T_J = 25^\circ C$	50			V/V

ELECTRICAL CHARACTERISTICS Unless otherwise stated, these specifications apply for $T_A = -40^{\circ}\text{C}$ to $+125^{\circ}\text{C}$, $V_{IN} = 5\text{V}$, $I_{SWITCH} = 0$, and $T_A = T_J$.

		UC2577-12			
PARAMETER	TEST CONDITIONS	MIN	TYP	MAX	UNITS
Device Parameters (cont.)					
Error Amplifier Output Swing	Upper Limit $V_{FB} = 10.0\text{V}$	2.0	2.4		V
	$T_J = 25^{\circ}\text{C}$	2.2			V
	Lower Limit $V_{FB} = 15.0\text{V}$		0.3	0.55	V
	$T_J = 25^{\circ}\text{C}$			0.40	V
Error Amp Output Current	$V_{FB} = 10.0\text{V}$ to 15.0V , $V_{COMP} = 10.0\text{V}$	± 90	± 200	± 400	μA
	$T_J = 25^{\circ}\text{C}$	± 130		± 300	μA
Soft Start Current	$V_{FB} = 10.0\text{V}$, $V_{COMP} = 0.5\text{V}$	1.5	5.0	9.5	μA
	$T_J = 25^{\circ}\text{C}$	2.5		7.5	μA
Maximum Duty Cycle	$V_{COMP} = 1.5\text{V}$, $I_{SWITCH} = 100\text{mA}$	90	95		%
	$T_J = 25^{\circ}\text{C}$	93			%
Switch Transconductance			12.5		A/V
Switch Leakage Current	$V_{SWITCH} = 65\text{V}$, $V_{FB} = 1.5\text{V}$ (Switch Off)		10	600	μA
	$T_J = 25^{\circ}\text{C}$			300	μA
Switch Saturation Voltage	$I_{SWITCH} = 2.0\text{A}$, $V_{COMP} = 2.0\text{V}$ (Max Duty Cycle)		0.5	0.9	V
	$T_J = 25^{\circ}\text{C}$			0.7	V
NPN Switch Current Limit	$V_{COMP} = 2.0\text{V}$	3.0	4.3	6.0	A
Thermal Resistance	Junction to Ambient		65		$^{\circ}\text{C/W}$
	Junction to Case		2		$^{\circ}\text{C/W}$
COMP Pin Current	$V_{COMP} = 0$		25	50	μA
	$T_J = 25^{\circ}\text{C}$			40	μA

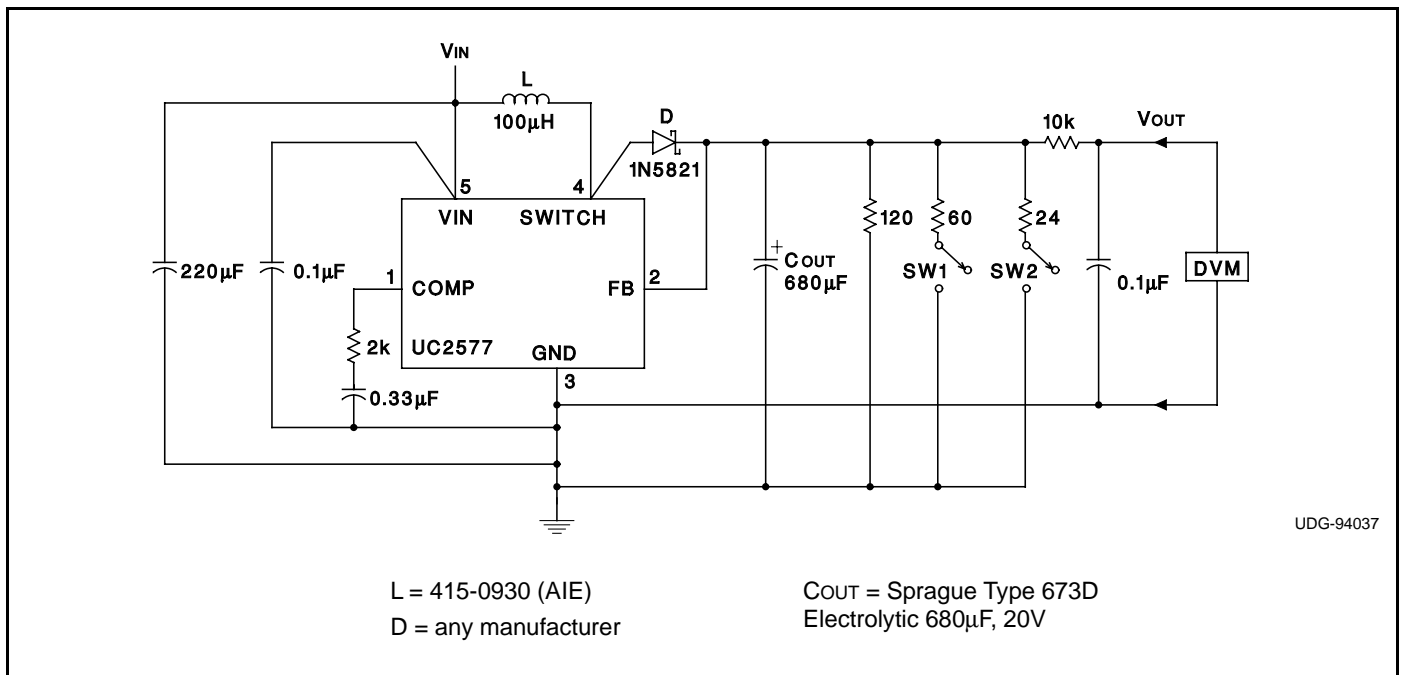

Figure 1. Circuit Used to Specify System Parameters

UC2577-15

ABSOLUTE MAXIMUM RATINGS (Note 1)

Supply Voltage	45V
Output Switch Voltage	65V
Output Switch Current (Note 2)	6.0A
Power Dissipation	Internally Limited
Storage Temperature Range	-65°C to +150°C
Lead Temperature (Soldering, 10 sec.)	260°C
Maximum Junction Temperature	150°C
Minimum ESD Rating (C = 100pF, R = 1.5kΩ)	2kV

RECOMMENDED OPERATING RANGE

Supply Voltage	$3.0V \leq V_{IN} \leq 40V$
Output Switch Voltage	$0V \leq V_{SWITCH} \leq 60V$
Output Switch Current	$I_{SWITCH} \leq 3.0A$
Junction Temperature Range	$-40^{\circ}C \leq T_J \leq +125^{\circ}C$

See Page 2 of this data sheet for Connection Diagram and Ordering Information.

ELECTRICAL CHARACTERISTICS Unless otherwise stated, these specifications apply for $T_A = -40^{\circ}C$ to $+125^{\circ}C$, $V_{IN} = 5V$, $I_{SWITCH} = 0$, and $T_A = T_J$.

		UC2577-15			
PARAMETER	TEST CONDITIONS	MIN	TYP	MAX	UNITS
System Parameters Circuit Figure 2 (Note 3)					
Output Voltage	$V_{IN} = 5V$ to $12V$, $I_{LOAD} = 100mA$ to $600mA$	14.25	15.0	15.75	V
	$T_J = 25^{\circ}C$	14.50		15.50	V
Line Regulation	$V_{IN} = 3.0V$ to $12V$, $I_{LOAD} = 300mA$		20	100	mV
	$T_J = 25^{\circ}C$			50	mV
Load Regulation	$V_{IN} = 5V$, $I_{LOAD} = 100mA$ to $600mA$		20	100	mV
	$T_J = 25^{\circ}C$			50	mV
Efficiency	$V_{IN} = 5V$, $I_{LOAD} = 600mA$		80		%
Device Parameters					
Input Supply Current	$V_{FB} = 1.5V$ (Switch Off)		7.5	14	mA
	$T_J = 25^{\circ}C$			10	mA
	$I_{SWITCH} = 2.0A$, $V_{COMP} = 2.0V$ (Max Duty Cycle)		45	85	mA
	$T_J = 25^{\circ}C$			70	mA
Input Supply UVLO	$I_{SWITCH} = 100mA$		2.70	2.95	V
	$T_J = 25^{\circ}C$			2.85	V
Oscillator Frequency	Measured at SWITCH Pin, $I_{SWITCH} = 100mA$	42	52	62	kHz
	$T_J = 25^{\circ}C$	48		56	kHz
Output Reference Voltage	Measured at FB Pin, $V_{IN} = 3.0V$ to $40V$, $V_{COMP} = 1.0V$	14.55	15	15.44	V
	$T_J = 25^{\circ}C$	14.70		15.30	V
Reference Voltage Line Regulation	$V_{IN} = 3.0V$ to $40V$		10		mV
FB Pin Input Resistance			12.2		kΩ
Error Amp Transconductance	$I_{COMP} = -30\mu A$ to $+30\mu A$, $V_{COMP} = 1.0V$	110	300	500	μmho
	$T_J = 25^{\circ}C$	170		420	μmho
Error Amp Voltage Gain	$V_{COMP} = 0.8V$ to $1.6V$, $R_{COMP} = 1.0M\Omega$ (Note 4)	20	65		V/V
	$T_J = 25^{\circ}C$	40			V/V
Error Amplifier Output Swing	Upper Limit $V_{FB} = 12.0V$	2.0	2.4		V
	$T_J = 25^{\circ}C$	2.2			V
	Lower Limit $V_{FB} = 18.0V$		0.3	0.55	V
	$T_J = 25^{\circ}C$			0.40	V
Error Amp Output Current	$V_{FB} = 12.0V$ to $18.0V$, $V_{COMP} = 1.0V$	±90	±200	±400	μA
	$T_J = 25^{\circ}C$	±130		±300	μA
Soft Start Current	$V_{FB} = 12.0V$, $V_{COMP} = 0.5V$	1.5	5.0	9.5	μA
	$T_J = 25^{\circ}C$	2.5		7.5	μA
Maximum Duty Cycle	$V_{COMP} = 1.5V$, $I_{SWITCH} = 100mA$	90	95		%
	$T_J = 25^{\circ}C$	93			%

ELECTRICAL CHARACTERISTICS Unless otherwise stated, these specifications apply for $T_A = -40^{\circ}\text{C}$ to $+125^{\circ}\text{C}$, $V_{\text{IN}} = 5\text{V}$, $I_{\text{SWITCH}} = 0$, and $T_A = T_J$.

		UC2577-15			
PARAMETER	TEST CONDITIONS	MIN	TYP	MAX	UNITS
Device Parameters (cont.)					
Switch Transconductance			12.5		A/V
Switch Leakage Current	$V_{\text{SWITCH}} = 65\text{V}$, $V_{\text{FB}} = 1.5\text{V}$ (Switch Off)		10	600	μA
	$T_J = 25^{\circ}\text{C}$			300	μA
Switch Saturation Voltage	$I_{\text{SWITCH}} = 2.0\text{A}$, $V_{\text{COMP}} = 2.0\text{V}$ (Max Duty Cycle)		0.5	0.9	V
	$T_J = 25^{\circ}\text{C}$			0.7	V
NPN Switch Current Limit	$V_{\text{COMP}} = 2.0\text{V}$	3.0	4.3	6.0	A
Thermal Resistance	Junction to Ambient		65		$^{\circ}\text{C/W}$
	Junction to Case		2		$^{\circ}\text{C/W}$
COMP Pin Current	$V_{\text{COMP}} = 0$		25	50	μA
	$T_J = 25^{\circ}\text{C}$			40	μA

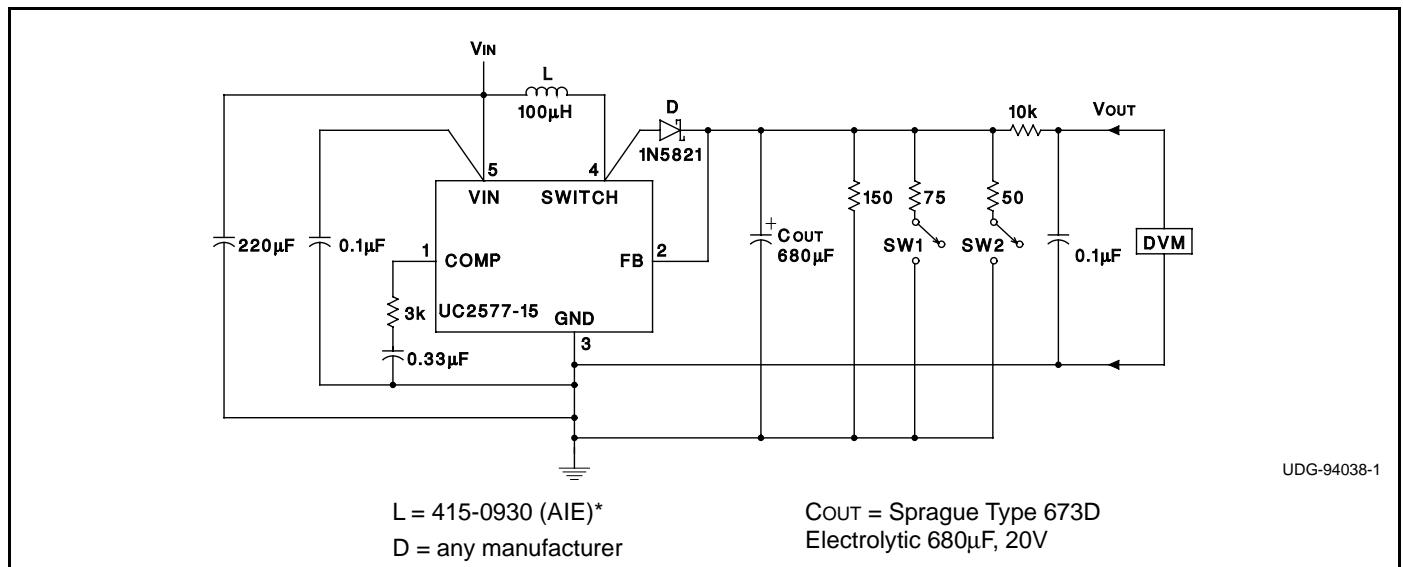

Figure 2. Circuit Used to Specify System Parameters

- Note 1:** Absolute Maximum Ratings indicate limits beyond which damage to the device may occur. Operating ratings indicate conditions during which the device is intended to be functional, but device parameter specifications may not be guaranteed under these conditions. For guaranteed specifications and test conditions, see the Electrical Characteristics.
- Note 2:** Output current cannot be internally limited when the UC2577 is used as a step-up regulator. To prevent damage to the switch, its current must be externally limited to 6.0A. However, output current is internally limited when the UC2577 is used as a flyback or forward converter regulator.
- Note 3:** External components such as the diode, inductor, input and output capacitors can affect switching regulator performance. When the UC2577 is used as shown in the Test Circuit, system performance will be as specified by the system parameters.
- Note 4:** A $1.0\text{M}\Omega$ resistor is connected to the compensation pin (which is the error amplifier's output) to ensure accuracy in measuring A_{VOL} . In actual applications, this pin's load resistance should be $\geq 10\text{M}\Omega$, resulting in A_{VOL} that is typically twice the guaranteed minimum limit.

*(AIE) is AIE Magnetics, Div. Vernitron Corp., 2801 72nd Street North, St. Petersburg, FL 33710. Tel. (813) 347-2181